

Booster Electric 6 KW – 54 KW



Standard Features:

- System Sentinel™ L.E.D. diagnostic system
- Immersion thermostats
- Manual reset high limit control
- 208, 240, 277 and 480 voltages
- 3 year limited tank warranty
- Magnetic contactors and integral fusing
- Heavy duty anode rods
- Durable brass drain valve
- Factory installed AGA/ASME rated T&P relief valve
- 6" stainless steel legs
- UL Sanitation compliant
- Certified for a 150 PSI max working pressure

Factory Accessories –

- Solid state low water cut-off
- Pressure reducing valve with bypass

RECOVERY CAPACITIES								
MODEL NUMBER	INPUT KW	EQUIVALENT BTU/HR.	TEMPERATURE RISE – DEGREES F – GPH					
			40°	60°	80°	100°	120°	140°
E10-6-G	6	20,473	62	41	31	25	21	18
E10-9-G	9	30,709	92	61	46	37	31	26
E10-12-G	12	40,946	123	82	61	49	41	35
E10-15-G	15	51,182	154	102	77	61	51	44
E10-18-G	18	61,418	184	123	92	74	61	53
E10-24-G	24	81,891	246	164	123	98	82	70
E10-27-G	27	92,128	276	184	138	111	92	79
E10-30-G	30	102,364	307	205	154	123	102	88
E10-36-G	36	122,837	369	246	184	147	123	105
E10-45-G	45	153,546	461	307	230	184	154	132
E10-54-G	54	184,256	553	369	276	221	184	158

Approximate Weight – 110 Lbs.

WATER TEMPERATURE RATINGS

Gallon Capacity	Thermostat Type	Minimum Delivered Temperature	Maximum Delivered Temperature	High Temperature Limit
10	Immersion	90°F	190°F	200°F

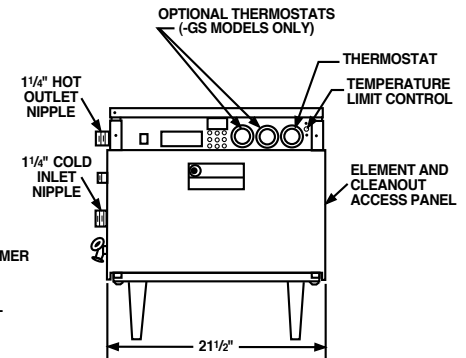
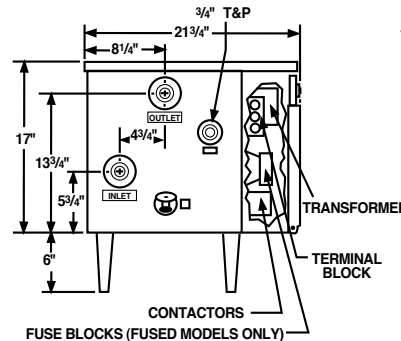

These models meet the energy efficiency levels of ASHRAE (Part of the Federally mandated Energy Policy Act (EPact)). Also exceeds energy efficiency codes of all states including California Energy Commission (CEC). All models are North Carolina Code compliant.